



BM5
SERIES
SLAM SHUT
VALVES



BM5 series slam shut valves

Axial flow slam shut valve with sleeve valve and manual reset

Introduction

BM5 series slam shut valve is an automatic shut-off appliance suitable for installation as safety device in regulating stations and gas distribution piping.

The slam shut valve has the task to quickly shut off the gas flow when the pressure in control point(s) reaches a fixed set value.

Advantages to our customers coming from the use of BM5 series slam shut valves are summarized below.

The valve is sleeve-type and as a consequence does not need any external by-pass to facilitate the opening of the valve itself.

The valve re-opening can be made only through a manual operation.



- Axial flow.
- Flanged connections.
- Sleeve valve.
- Protected seal pad.
- Possible to fit in all positions.
- Pressure control in one or more points of the installation.
- Starting up following overpressure and/or underpressure.
- Push-button manual emergency release.
- Manual reset through rotation of the reset shaft only.

BM5 series slam shut valves



Construction features

Nominal diameters available (mm): DN: 25 - 40 - 50 - 65 - 80 - 100 - 150.

PN 16, PN 25, (UNI 2282) and ANSI 150, ANSI 300, ANSI 600 (ASME/ANSI B16.5) flanged connections. Flanges are normally supplied with step.

ANSI flange coupling surfaces are finished with semicircular profile phonographic groove.

UNI flange coupling surfaces are finished with three semicircular profile concentric grooves.

On request, they can be both supplied with smooth finish.

Available types

Low temperature

This version is available in all configurations and all diameters and is supplied with seals and NBR rubber elements for low temperature.

Sour gases

For use with sour gases, a version complying with NACE standards is produced.

This version is available for DN 50, 65, 80, 100 only and is not possible to have the OS/80X-PN pilot controlled by servopilots.

The application range is represented by "A" zones in the following graph:

Application graph

The red line divides the graph into two zones.

The zone "A" indicates the range where it is necessary to use the sour gases version.

The zone "B" indicates the range where this version is not necessary.

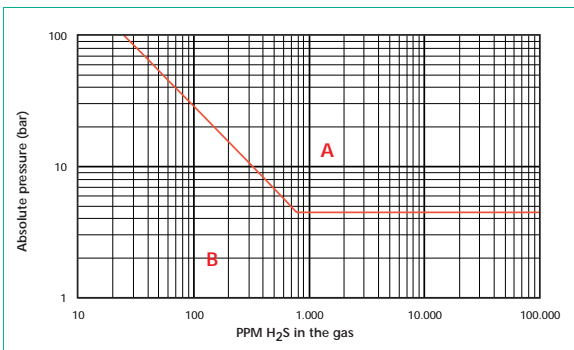

Application

BM5 slam shut valve is used in natural gas regulating installations and air, propane, butane, LPG, city gas, nitrogen, carbon dioxide, hydrogen regulating or distribution installations.



BM5 series slam shut valves

Functional specifications

BM5 series slam shut valve is essentially made of an axial flow valve and a pilot allowing to keep the valve open.

The valve body features a sleeve valve (O) sliding axially and as a consequence no by-pass is needed for its opening even in the presence of pressurized gas.

The valve opening can be made only manually by turning the eccentric shaft (A) anticlockwise.

The seal pad is not hit by the gas flow since it is protected by the pad holder (P) and as a consequence is not affected by any possible dirt present in the gas.

When the controlled pressure is within set values of the pilot, this remains set and prevents the rotation of the eccentric shaft (A).

When this pressure varies beyond setting limits, the pilot releases the eccentric shaft and the valve (O) is brought to its closing position following the spring (M) thrust.

The pilot is provided with a manual release push-button to quickly close the slam shut valve in case of emergency or during maintenance/checking operations.

Should the valve be used with pilot-operated pressure regulators, the supply to pilots should be taken downstream of the slam shut valve.

For this purpose, BM5 valves feature a threaded hole to be used for supply to pilots; the hole is normally kept closed by a dowel.

The supply to pilots can be made through a standard joint or through the suitable stud supplied on request.

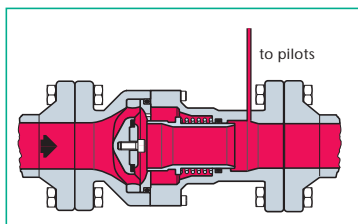

Materials

Standard type

Half-bodies	ASTM A 105 Steel
Valve	Fe 510 UNI 7729 Steel
O-Ring	NBR rubber (*)
Pad	NBR rubber (*)
Pad holder	39 Ni Cr Mo3 UNI 7874-79 Steel
Screws	UNI 3740 Class 8.8

(*) Viton on request

BM5 series slam shut valves

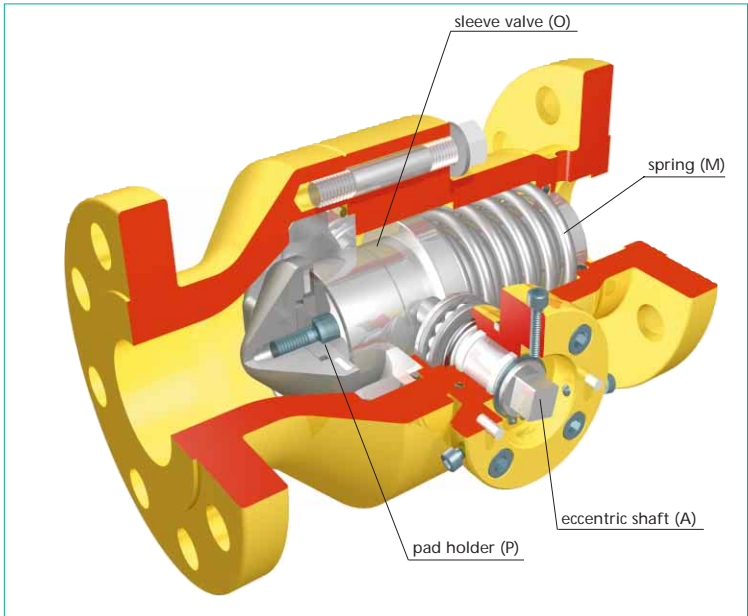

Technical and functional specifications (pressures in bar)

Flange rating		PN 16	PN 25	ANSI 150	ANSI 300	ANSI 600
Allowable pressure	P_{zul}	16	25	20	50	100
Design pressure	P_d	16	25	20	50	100
Hydraulic test		24	37.5	30	75	150
Permissible inlet pressure	$P_{e,max}$	16	25	19	50	100
Inlet pressure range	b_{pe}	0 ÷ 16	0 ÷ 25	0 ÷ 19	0 ÷ 50	0 ÷ 100
Overpressure set range	W_{ho}	0.03 ÷ 16	0.03 ÷ 25	0.03 ÷ 19	0.03 ÷ 50	0.03 ÷ 80
Underpressure set range	W_{hu}	0.01 ÷ 16	0.01 ÷ 25	0.01 ÷ 19	0.01 ÷ 50	0.01 ÷ 80
Accuracy class	AG			up to 1		
Response time	t_a			≤ 1 s		

Temperature

Standard type and sour gases type

- working temperature -10 °C +60 °C
- ambient temperature -20 °C +80 °C

Low temperature type

- working temperature -20 °C +60 °C
- ambient temperature -30 °C +80 °C



BM5 series slam shut valves

Calculation procedures

Symbols In the formulas below, following symbols are used:

Q = Flow rate in Stm^3/h
 P1 = Absolute inlet pressure in bar
 P2 = Absolute outlet pressure in bar
 ΔP = Power loss in bar
 C_g = Flow rate coefficient
 C1 = Form coefficient

Flow rate calculation

In critical state with $P2 \leq \frac{P1}{2}$: $Q = 0.525 \cdot C_g \cdot P1$

In subcritical state with $P2 > \frac{P1}{2}$: $Q = 0.525 \cdot C_g \cdot P1 \cdot \text{sen} \left(\frac{3417}{C1} \cdot \sqrt{\frac{P1-P2}{P1}} \right)^\circ$

Note: The sine argument is expressed in sexagesimal degrees.

Power loss calculation

$$\Delta P = \frac{P1 \cdot \sqrt{P1^2 - 4 \cdot \left(\frac{Q}{C_g \cdot 1.05} \right)^2}}{2}$$

Flow rate coefficients

DN	C_g	C1
25	525	29
40	1420	28
50	2250	26
65	3600	28
80	5400	30
100	8700	26
150	18600	28

This formula can be applied only for flow rates lower than the maximum flow rate calculated with P1.

Formulas are valid for natural gas only. For other gases, multiply the flow rate by the following correction factors:

Air	= 0.78
City gas	= 1.17
Butane	= 0.55
Propane	= 0.63
Nitrogen	= 0.79
Carbon dioxide	= 0.63
Hydrogen	= 2.93

Choice of the slam shut valve diameter

Calculate the necessary C_g by using the following formula: $C_g = \frac{Q}{0.525 \cdot P1 \cdot \text{sen} \left(120 \cdot \sqrt{\frac{P1-P2}{P1}} \right)^\circ}$

Note: the above formula is valid only with flow rate referred to natural gas. For other gases, divide the flow rate by the correction factor.

Choose the slam shut valve with the C_g higher than the calculated value. (see table)

After having determined the slam shut valve diameter, it is suggested to check that the velocity on the seal seat is not higher than 120 m/sec. by using the following formula:

$$V = 345.92 \cdot \frac{Q}{DN^2} \cdot \frac{1 - 0.002 \cdot P_e}{1 + P_e}$$

V = velocity (m/s)
 345.92 = numerical constant
 Q = flow rate under standard conditions (Stm^3/h)
 DN = valve nominal diameter (mm)
 P_e = inlet pressure in relative value (bar)

In case of velocities higher than indicated limits, increase the valve diameter.

BM5 series slam shut valves



Pilots

With BM5 series slam shut valves the following devices can be used:

- OS/80X Series - spring-loaded pneumatic device
- OS/80X-PN Series - PRX series servopilot-operated pneumatic device

For their operation, these pilots use the gas in the piping and thus do not need any external source.

Pilots can be preset for their starting up due to overpressure and underpressure or overpressure only or underpressure only.

OS/80X Series Pilot

In the pilot chamber (C) there is the controlled pressure which, under standard working conditions, is opposed to the overpressure spring load (M1) and wins over the underpressure spring load (M2).

Under these conditions, the leverage system (L, L1, L2) is hooked up and prevents the rotation of the lever (L3) integral to the shaft (A); the pilot is thus reset and keeps the valve (O) open.

If, because of any failure, the controlled pressure reaches the value set for the slam shut valve starting up, the lever (L) moves and, by pushing on lever (L1) projections, releases the bracket (L2).

The shaft (A) can rotate and the valve, following the thrust of the spring (M), is brought to its closing position (see figure at page 5).

By removing the spring (M2), OS/80X series pilot can be used for overpressure only.

To use it for underpressure only, it is sufficient to tighten the ring nut (R1) until the spring (M1) is fully loaded.

The OS/80X series pilot is supplied in different models according to set ranges required.

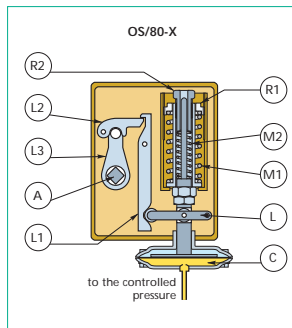

BM5 series slam shut valves



Construction and functional specifications of OS/80X Series and OS/80X-PN Series Pilots

Pressures in bar

Type	Servomotor body resistance	Overpressure set range	Underpressure set range
OS/80X-BP	5	0.03 ÷ 2	0.01 ÷ 0.60
OS/80X-BPA-D	20	0.03 ÷ 2	0.01 ÷ 0.60
OS/80X-MPA-D	100	0.50 ÷ 5	0.25 ÷ 4
OS/80X-APA-D	100	2 ÷ 10	0.30 ÷ 7
OS/84X	100	5 ÷ 41	4 ÷ 16
OS/88X	100	18 ÷ 80	8 ÷ 70
OS/80X-PN	100	0.5 ÷ 40	0.5 ÷ 40
OS/84X-PN	100	30 ÷ 80	30 ÷ 80*

* On request, the underpressure set value can be reduced to 10.

OS/80X pilot materials

Servomotor body	OS/80X-BP	GD Al Si 12 Cu2Fe UNI 5076-74 Aluminium
	OS/80X-BPA-D	P Al Cu5.5 Pb0.4 Bi0.4 UNI 9002/5-89 Aluminium
	OS/80X-MPA-D	ASTM A 105 Steel
	OS/80X-APA-D	ASTM A 105 Steel
Diaphragm		Linen NBR/PVC rubber
O-Ring		NBR rubber

OS/84X and OS/88X pilot materials

Servomotor body	P-Cu Zn40 Pb2 UNI 5705-65 Brass
Lip seal	Teflon (PTFE)
O-Ring	NBR rubber

PRX series pilot materials

Body	CF9 5 Mn Pb28 UNI 4838-80 Steel
Diaphragm	Linen NBR rubber
O-Ring	NBR rubber

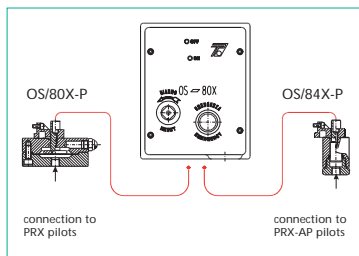
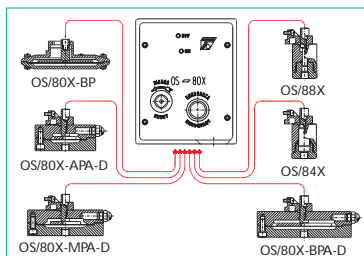



BM5 series slam shut valves

Pressure and accuracy ranges

The reset differential indicates the minimum value to keep as compared to the line set point for the correct pilot reset.

Example: line set point 3 bar.

The choice is for an OS/80X-MPA-D with red spring, overpressure set value 3.5 bar or higher, underpressure set value 2.3 bar or lower.

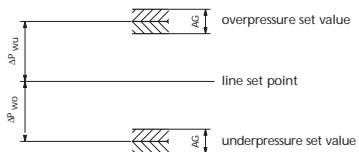

Model	Spring Colour	Overpressure range W_{ao} (bar)	Reset Differential ΔP (bar)	Underpressure range W_{au} (bar)	Reset Differential ΔP_{WU} (bar)	AG - 20 °C		AG - 10 °C	
						max.	min.	max.	min.
OS/80X Series									
OS/80X-BP	Black	0.03 + 0.07	0.015	0.01 + 0.03	0.01	10	20	2.5	10
OS/80X-BPA-D	Aluminium	0.07 + 0.15	0.03	0.03 + 0.07	0.02	10	20	2.5	10
	Yellow	0.15 + 0.30	0.04	0.07 + 0.14	0.03	5	15	2.5	10
	Blue	0.30 + 0.70	0.07	0.13 + 0.40	0.06	5	15	1	5
	Red	0.70 + 2	0.15	0.40 + 0.60	0.20	2.5	10	1	5
OS/80X-MPA-D	Yellow	0.50 + 0.70	0.15	0.25 + 0.40	0.15	10	20	2.5	10
	Blue	0.70 + 2.50	0.30	0.40 + 0.90	0.30	5	15	1	5
	Red	2.50 + 5	0.50	0.90 + 3.5	0.70	5	15	1	5
OS/80X-APA-D	Yellow	-	-	0.30 + 0.80	0.25	-	15	-	10
	Blue	2 + 4	0.40	0.80 + 2	0.50	5	15	1	5
	Red	4 + 10	1	2 + 7	1.50	2.5	10	1	5
OS/84X	Blue	5 + 25	3	4 + 8	3	5	15	1	5
	Red	24 + 41	5	7 + 16	6	2.5	10	1	5
OS/88X	Yellow	18 + 50	8	8 + 30	8	2.5	10	1	5
	Blue	40 + 80	12	20 + 70	15	2.5	10	1	5
OS/80X-PN Series									
PRX/181	Yellow	0.5 + 1.5	0.2	0.5 + 1.5	0.3	2.5	2.5	1	1
PRX/182	Green	1 + 3	0.3	1 + 3	0.4	2.5	2.5	1	1
	Black	2 + 8	0.4	2 + 8	0.6	2.5	2.5	1	1
	Gold	5 + 20	0.5	5 + 20	0.6	1	2.5	1	1
	Red	15 + 42	0.6	15 + 42	0.8	1	2.5	1	1
PRX-AP/181	Neutral	30 + 80	0.8	30 + 80	1	1	1	1	1
PRX-AP/182									

Pilot reset

The reset operation is possible only manually by simply rotating the shaft (A) (see figures at page 7 and 8).

- Introduce the reset lever and slowly rotate it anticlockwise until the valve opens completely.
- Keep the lever in this position and wait for the outlet pressure stabilization. Make the shaft rotate a couple of times by making sure that the leverage keeps the pilot set.
- If the reset results to be uncertain or the pilot does not remain set, check connections, setting and eventually proceed to its maintenance.

Pilot setting

OS/80X Series

Overpressure or underpressure values are adjusted independently by means of adjusting screws (R1) and (R2) of springs (M1) and (M2) respectively (see figure at page 7).

OS/80X-PN Series

Its setting is executed by means of PRX/182 pilot adjusting screws for overpressure starting up values and PRX/181 for underpressure.

The pilot is supplied already preset for normal operation and thus does not need any setting.

BM5 series slam shut valves



Accessories

NAMUR type proximity switch

In order to send the slam shut valve opening/closing signal, a proximity switch suitable for installation in hazardous area is used.

The use of this switch foresees the application of an intrinsic safety separation barrier which should be installed in safe area.

The distance between the proximity switch and the barrier should be calculated according to the type of gas and installation electrical specifications.

On request it is possible to supply the version with two proximity switches in order to indicate the positions of the valve opening/closing.

Technical data

IP 67 protection class in compliance with IEC 529 standards.

EEx ia IIC T4 protection mode in compliance with CENELEC EN 50014, 50020.

CESI EX-92.C.100 certificate of conformity

Working temperature	- 25 °C up to + 110°C
Maximum current	≤ 100 mA
Starting up distance	≤ 1.5 mm
Applicable voltage	≤ 13.5 V
Applicable load	≤ 2 mA
Cable length	2 m

Separation barrier for digital signals

Among the different separation barriers presently available, the installer can choose the one which most suits the installation design.

We suggest the use of μ D type separation barrier available in two models.

Single channel separation barrier μ D 411
Two channel separation barrier μ D 412

Technical data

[EEx ia] IIC protection mode in compliance with CENELEC EN 50014, 50020 standards.

CESI EX-95.D.025 certificate of conformity.

Working temperature	0 °C up to +60 °C
Storing temperature	-20 °C / +70 °C
Power supply	98/250 V - AC 20/30 V - DC
Relay type output	110 V / 0.3 A - DC 48 V / 0.5 A - DC 24 V / 2 A - DC

Installation of the barrier

The distance between the switch and the barrier should be calculated according to the type of gas and installation electrical specifications.

In applications with natural gas, the connection between the proximity switch and the μ D barrier can be executed with conductors featuring the specifications below.

Technical data

Wire section	1 mm ²
Isolation	3 kV
Resistance	0.0195 Ω /m
Inductance	0.001 mH/m
Capacity	0.0002 μ F/m
Maximum length	200 m



BM5 series slam shut valves

EL/3 type solenoid valve for remote closing

In addition to the normal use, i.e. to guarantee the installation safety against any possible pressure increase and/or reduction, BM5 slam shut valves can be also provided with a 3-way valves in explosion proof execution which allows the opening of the valve itself through a remote control.

This solenoid valve can be applied both to the OS/80X and OS/80X-PN when these are foreseen for underpressure starting up.

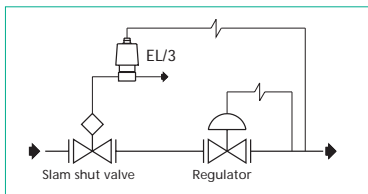

For the complete definition of the model, always indicate the supply voltage.

Example: EL/3 - 220 V / 50 Hz

IT/3V 3-way valve for setting control

BM5 slam shut valves can be provided with a 3-way valve to control the pilot operation and setting without varying the regulator setting.

IT/3V 3-way valve is spring-loaded type and is equipped with a plate for safety lock.

The pressure on the control knob permits the sensitive element to communicate with a pressure source by allowing to execute operation or setting tests.

Upon completion of operations, the knob release allows to restore standard working conditions.

Technical data

IP 65 protection class in compliance with IEC 144 standards.

EEx d IIB T3 protection mode in compliance with CENELEC EN 50014, 50018 standards.

CESI AD-89.B.047 certificate of conformity.

Permissible inlet pressure	24 bar
Ambient temperature	-10 °C +55 °C
Gas temperature	-10 °C +90 °C
Orifice	0.8 mm
Mass	0.8 kg
Voltagess available	110 - 220 V / 50 - 60 Hz 12 - 24 V - DC

Built-in electrical terminal board with internal and external earth outlet.

Body in AISI 316 stainless steel.

Seals in VITON

Connections for 1/4" NPT female pneumatic fittings.

Connection for 1/2" NPT female explosion proof installation.

Technical data

Permissible inlet pressure	50 bar
Ambient temperature	-20 °C +60 °C
Orifice	6 mm
Mass	0.5 kg

Body in GD Al Si2 Cu2 Fe UNI 5076 die-cast aluminium.

Seals in NBR rubber.

Connections for 1/4" NPT female pneumatic fittings.

Connection on piping: R 3/4" UNI ISO 7/1.

BM5 series slam shut valves



Installation

BM5 series slam shut valves can be installed on the piping with both horizontal axis and vertical axis and with any gas flow orientation.

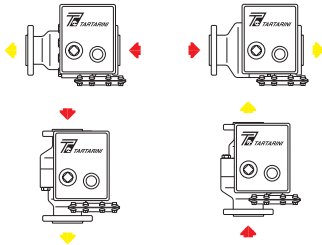

The pilot can be turned by 90° steps to allow the orientation in vertical position with the adjusting screws turned upwards in order to obtain an optimal operation and an easier setting control.

This slam shut valve has been designed to work even in the presence of relatively dirty gas since the seal pad is not hit directly by the gas flow. However, being a safety device, it is suggested to install a filter upstream of it.

Installation example in a low pressure regulating unit

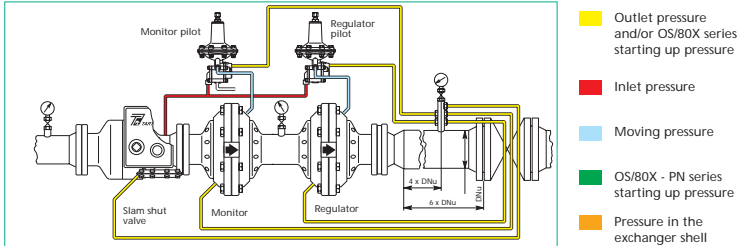

Installation example to control the overpressure and underpressure downstream of regulators and the pressure in the exchanger shell.

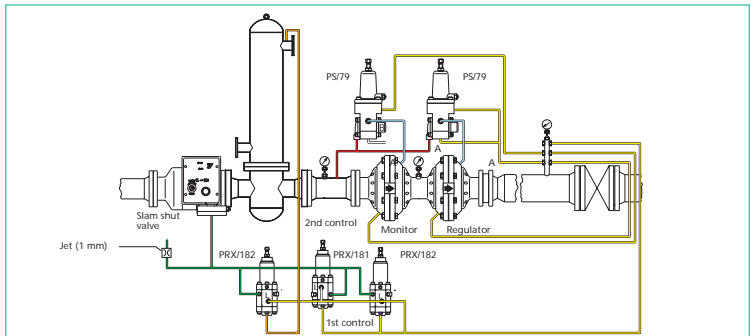



BM5 series slam shut valves

Overall dimensions (mm)

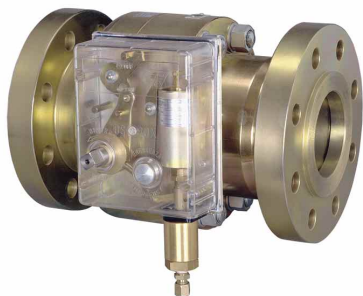

Type/DN	BM5/25	BM5/40	BM5/50	BM5/65	BM5/80	BM5/100	BM5/150
A	100	125	145	155	165	195	250
B	220	235	245	255	275	295	365
C	200	205	215	225	245	270	380
D	125	155	165	190	230	275	410
E	260	280	300	320	360	410	585
I PN 16	184	222	254	276	298.5	352.5	451
I PN 25	184	-	254	-	298.5	352.5	451
I ANSI 150	184	222	254	276	298.5	352.5	451
I ANSI 300	197	235	266.5	292	317.5	368.5	473
I ANSI 600	210	251	286	311	336.5	394	508

Note: Dimensions C are indicative and refer to models with the greatest overall dimensions.
The threaded hole for the control piping connection is 1/4" NPT female.

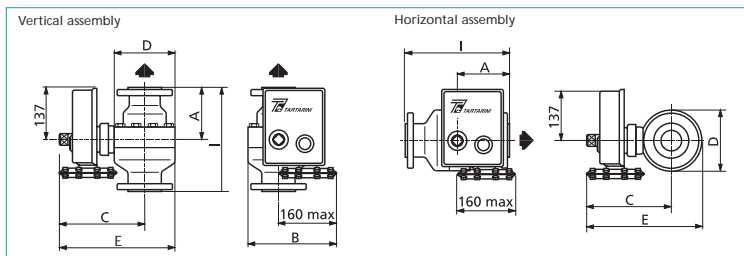

Weights [in Kg]

Type/DN	BM5/25	BM5/40	BM5/50	BM5/65	BM5/80	BM5/100	BM5/150
PN16/25 - ANSI150	15	21	26	38	54	83	170
ANSI 300/600	17	25	30	41	62	105	280

Weight of the valve complete with pilot

BM5 series slam shut valves



Purchase description

To order the slam shut valve, specify:

- valve,
- pilot,
- any possible accessory.

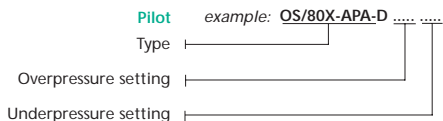
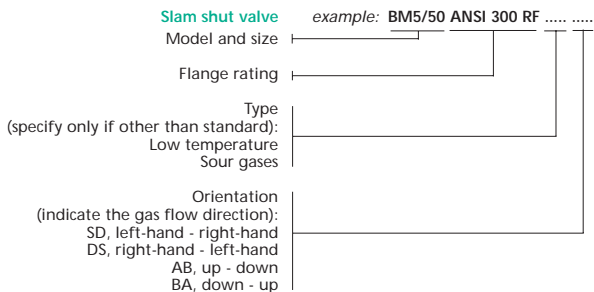

Accessories

- Proximity switch
- Separation barrier: eg. μ D 411- 98/250 V-AC
- Solenoid valve: eg. EL/3 - 24 V - DC
- IT/3V 3-way valve





**O.M.T. Officina Meccanica
Tartarini S.p.A.**

Via P. Fabbri, 1
I-40013 Castel Maggiore (Bologna) Italy
Tel.: +39 - 0514190611
Fax: +39 - 0514190715
E-mail: tartarini@tartarini.it
www.tartarini.it

Gas pressure regulating and metering stations. Pressure regulators, slam-shut valves, safety valves and accessories. Remote control equipment. Engineering, adaption of existing installation to meet current standard requirements. Theoretical and practical training.



Complete kits, vaporizers and accessories for the conversion of petrol engines to natural gas and lpg.

GB 181-06/99

Information and data contained in this publication are merely indicative; therefore, we do not take any responsibility for use. We reserve the right to make any possible change without prior notice.